INSTRUCTION MANUAL
OF GEARLESS PMS
ELEVATOR TRACTION MACHINE

VERSION: A1

DATE: JAN., 2018

Contents

1. Foreword.....	2
2. General descriptions and notice	2
3. Product structure and operating principle	4
4. Operating conditions of the traction machine	4
5. Examinations before operating.....	5
6. Installation of the traction machine.....	6
7. Installation size of the traction machine.....	6
8. Operation of the traction machine	6
9. Adjustment of the brake	6
10. Maintenance and notice.....	7
Appendix 1 The traction machine general problems and solution.....	12
Appendix 2 Installation and deinstallation of the encoder.....	13
Appendix 3 Instruction of the elevator hand-winding device.....	16
Appendix 4 Method of change the traction machine operation direction.....	18

1. Foreword

Thank you for choosing the gearless permanent magnet synchronous elevator traction machine.

The instruction manual tells you how to use the gearless permanent magnet synchronous elevator traction machine correctly. Please read the instruction manual carefully, before you do any operations (transportation, installation, maintenance, check and son on), and use the machine after you know the product notice well.

2. General descriptions and notice

[1] General descriptions

- The figures of this instruction manual are the general descriptions, maybe different from the product you get.
- The instruction manual would have proper changes, for the improvement etc.
- The instruction manual, if it is damaged or any page out, please contact with us or the agent.
- The statement of the safe sign



NOTICE It means the wrong usage would cause the machine potential damage or any other components damage.



DANGER It means the wrong usage would cause property loss, personal injury or dead and other accidents.

The items with safe sign are very important, please observe it strictly!

[2] Notice



NOTICE

- Check if the model is you ordered, if not, do not install it.
- Do not put your hands or goods on the move parts or the warning parts.
- Do not use the machine with problems.
- Do not take the nameplate off, or cover it.
- When lifting, please use the rings (or the rings on the machine) carefully, and make sure the machine do not connect with the other installing equipment. Before lifting, do check the machine's weight and the load of the lifting equipment.
- Do not put flammable goods by the machine, and make sure it has necessary space to send out the heat.
- The machine must be supplied by the special transducer, do not connect it with the power or the improper drive equipment directly.
- Make sure if all the fasteners are strong before installation.
- When installing, notice the machine operating direction and the elevator running direction should be the same.
- Stop the machine running when there is problem.
- Inspection and maintenance should be done by the professional persons.
- Do not use shaking or impacting tools on the machine.



DANGER

- Do not use the machine in flammable and easy explosive gas.
- Do not operate it when the power is on, do turn off the power, then operate it.
- Operation should be done by the professional persons.
- When connect with the power, please do as the manual request.
- Be sure to be earthed reliably.
- Do not operate when the cover of terminals is open.
- Do not approach the rotating parts when it is operating.
- The brakes must be checked by the professional persons before operating. If there are any problems, please adjust it strictly by the professional persons according to

the braking system instruction manual.

- When adjusting the brake, please take measure to ensure that the car and the counterpoise cannot move.
- Do not change the product.
- If the site maybe drips water or oil, be sure that the machine can work. Otherwise, do not install it.

3. Product structure and operating principle

The gearless permanent magnet synchronous (PMS) traction machine consists of PMS motor, traction sheave and braking system. The PMS motor is made up of high-performance PM materials, it has special structure, and it has low speed and large torque characteristics. The braking system is made up of the brake, brake wheel etc. The traction machine operating principle is that the motor power produce torque to traction sheave and the friction between the traction sheave and the rope drives the elevator running. The normal closed brake should skid the brake wheel to keep the elevator holding still when the elevator stop running.

All the functions of the traction machine are according to <EN81-1:1998>, <GB7588-2003> and <GB/T24478-2009>. Before shipping, each traction machine has to be strictly inspected, such as motor output torque, braking force, insulated voltage, mechanical vibration, noises, etc, thereby ensure the product qualities and functions up to standard.

4. Operating conditions of the traction machine

[1] Height above sea level does not exceed 1000m. If the height is more than 1000m, revision Shall be carried out according to the relevant provisions of the GB755 -2008.

[2] Ambient air temperature should be kept in 5~40 ℃.

[3] The site air relative humidity should not exceed 50% when the highest temperature is 40 °C. It may have higher relative humidity at lower temperature. The average lowest temperature in the wet month should not exceed +25 °C; the average biggest relative humidity of this month should not exceed 90%. If it may have condensation on the machine, then it should take some measures.

[4] Environmental air should not contain corrosive and inflammable gas.

[5] Steel rope diameter \leq fortieth of traction sheave diameter, and without any lubricant and sundries on its surface.

[6] The traction machine must be supplied by the special transducer, and work in the closed-loop control mode. Rated parameters of the traction machine are according to the nameplate on the machine shell. It is forbidden to supply the power to the machine directly, to avoid burning the machine.

[7] Deflection between fluctuation of working frequency and rating amount not exceed to $\pm 7\%$.

5. Examinations before operating

[1] Check if the packing is perfect, and if there are any damp signs, when opening.

[2] Check the nameplate carefully, and judge if the machine meets the requirements.

[3] Check if there is any damage of the machine, if the fastening pieces are loose or fall off, if the braking system is flexible.

[4] Make sure that the install surface is horizontal, and is has enough mechanical strength and the corresponding measures to reduce vibration.

[5] Test the motor stator windings by 1000V megohmmeter, the hot insulation

resistance should not less than $0.5\text{M}\Omega$ and the cold insulation resistance should not less than $5\text{M}\Omega$. Otherwise, it should be dried.

[6] It should have special grounding terminals at the installing site, and the earth-resistance is less than 10Ω . The machine should be earthed well. You may use the bottom fastening bolts to earth ground when necessary.

6. Installation of the traction machine

[1] The installation must strictly executed according to the installing drawings offered by the elevator manufactory, to make sure the elevator traction conditions meet the design requirements.

[2] The machine must be lifted and installed in a whole, it is forbidden to take apart of it.

[3] Installing plane of the traction machine not only ensure level, but also have to take corresponding weakening vibration measures.

7. Installation size of the traction machine

Please refer to the sample.

8. Operation of the traction machine

Please refer to the connecting line methods inside of the cover of junction box.

9. Adjustment of the brake

The adjustment method of the brake refer to the braking system instruction manual.

10. Maintenance and notice

[1] Maintenance

1.1. Keep the machine room clean and dry.

1.2. Keep the traction machine surface clean.

1.3. Keep a constant check, check for the brake flexibility, the braking pad and the traction sheave worn, and the bearings. Replace worn and damaged parts when necessary.

1.4.

1.4.1 For the traction machine with non oil label, They use sealed bearing, no need to maintain, no need to add grease. When it is damaged, replace it with the same type.

1.4.2 For the traction machine with oil label, the bearing beside oil label is non sealed bearing and must be oiled periodic lubrication through the oil cup on the front cover. Please see the oil label(Rotate the traction sheave and you can see a the oil label on the front cover) for the more information. Oil injection method: Rotating the traction sheave and you can see a oil cup on the front cover, and oil the bearing with oil gun through the oil cup or remove the hexagon socket set screw M10×1 on grease cup, then oil the bearing with oil gun through the screwed hole.

1.4.3 For the traction machine with oil label and no grease cup, the oil injection method is as follows. There is a oil label on the front face of the brake pulley, beside the label there is a hexagon socket set screw M20*1.5, remove the screw, turn the traction sheave, look through the hole of the screw while turning, stop turning while watched a hexagon socket set screw M10*1 (not hexagon socket head cap screw), remove the screw M10×1,then oil the bearing with oil gun through the screwed hole, see figure 10.1.

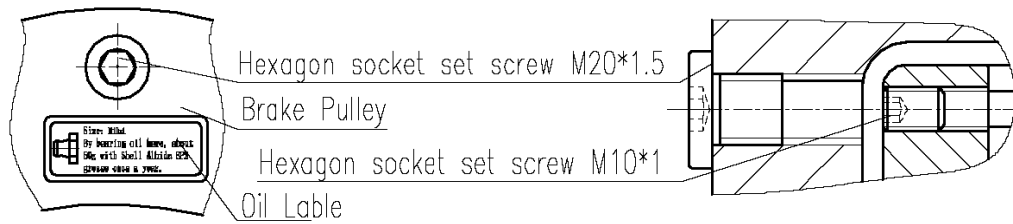

Fig.10.1

1.4.4 Cylindrical roller bearing is a non-sealed bearing, oil way refer to the illustration below . When it is damaged, replace it with the same type.

Non-sealed bearing grease injection mode:

1.4.4.1 Tools

M10 screw with socket head wrench, plastic scraper, oil gun

1.4.4.2 Grease injection frequency

The machine has been injected with some grease before delivery, to maintain normal running of the bearing, the open-type bearing should be injected grease at least once a year. If the bearing be caused by lack of oil for other reasons, it should be added grease timely.

1.4.4.3 Non-sealed bearing grease injection method.

1.4.4.3.1 Construction site can remove the rotor assembly.

1.4.4.3.1.1 Remove the outer gland with Allen wrench on the M10 socket head cap screw, remove the rotor assembly from the machine, you can see open-type bearing NJ226 on the surface, as shown in figure 10.2.

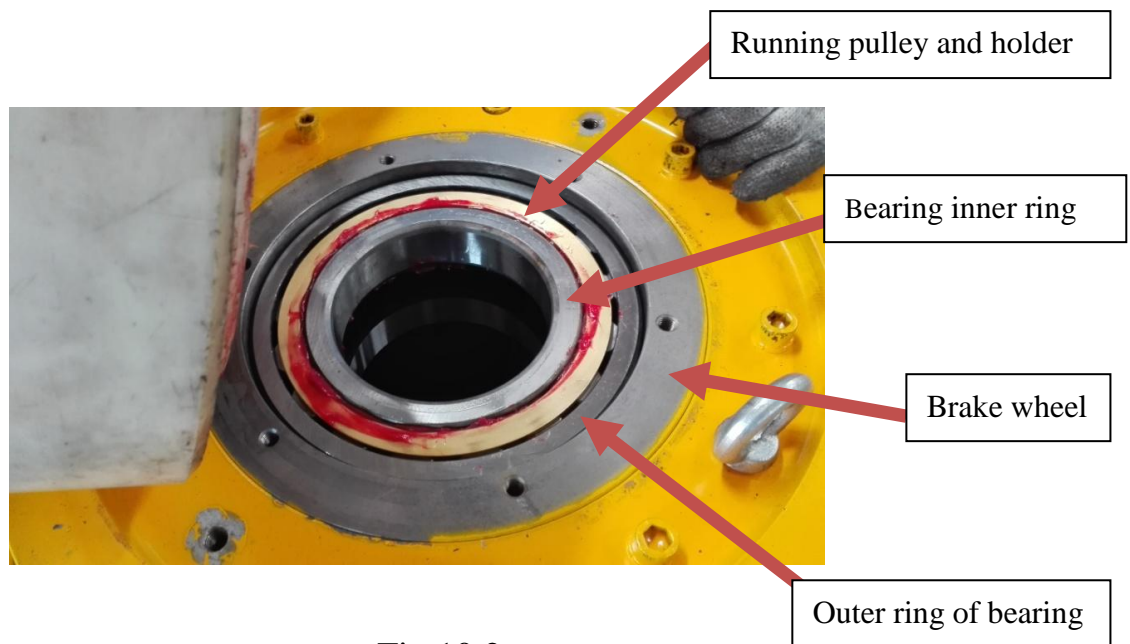

Fig.10.2

1.4.4.3.1.2 Remove the bearing inner ring from the rotor assembly by hand, outer ring of bearing and running pulley are contacted with brake wheel, the separation of bearing inner ring and outer ring is as shown in figure 10.3.



Fig.10.3

1.4.4.3.1.3 After removing the inner ring, you can smear Albide EP2 grease in running pulley with scraper blade (sheet plastic), grease quantity reference figure.

10.4.



Fig.10.4

NOTICE! If aftermarket site do not have Albide EP2 grease, in order to ensure the grease lubrication characteristics, you can use alcohol to clean up the original grease inside the bearing after with dry cloth, and then smear new grease.

1.4.4.3.1.4 After the oil coating you can assemble the machine according to the adverse steps.

1.4.4.3.2 Construction site can not remove the rotor assembly

If you want to injection grease ,but you can not remove the rotor assembly from the machine, you can strike the outer gland, come out NJ226 bearing, and then you can injection grease with grease gun alignment running pulley gap, as shown in attached figure 10.5, injection amount of grease need to fill gaps, you can inject grease for other roller clearance take the same way, please assemble outer gland after injecting grease.

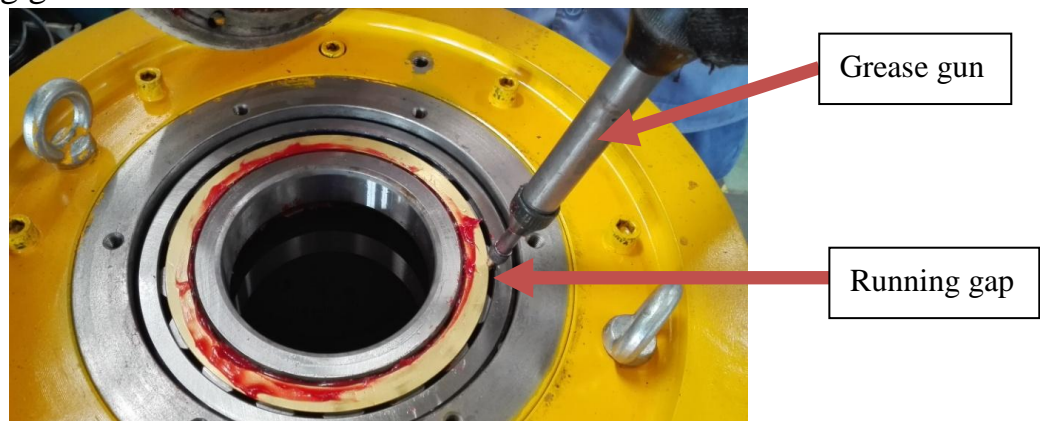

Fig.10.5

[2] Notice

2.1 If you want to take damageable parts apart, please contact us, and let professionals do it .If you do it by yourself, it may cause serious accident.

2.2 The machine operating temperature must not exceed 130°C. it may be controlled by thermo switch(Work temperature: 130°C \pm 5K; Max work voltage: 500VAC; Rated current: 2.5A). The machine should be stopped when the temperature is up to 130°C.

2.3 The machine would generate electricity when it is rotated passively, and there is higher voltage on the machine terminals. Pay attention to getting electric shocked and equipment damaged.

2.4 The interface between brake pad and brake wheel should avoid oil or any other impurity, or it would cause the braking force dropping.

2.5 The traction machine brake system with a micro switch feedback brake action state, the control system must monitor the brake switch, to ensure safe and reliable operation of the traction machine.

Appendix 1 The traction machine general problems and solution

No.	Problems	Solution
1	When open the brake, the braking pad rub the brake wheel.	<ol style="list-style-type: none"> 1. Check the voltage 2. Check the braking air gap 3. Check the adjustable bolts
2	The two brakes can not work simultaneously.	<ol style="list-style-type: none"> 1. Check the voltage 2. Check if the two sides braking air gap is the same
3	The machine current exceeds the rated.	<ol style="list-style-type: none"> 1. Check if the encoder is loosening. If it is, the encoder should be fixed again, and begin self study 2. Search the reason
4	The machine shakes abnormally, and it has too much noise.	<ol style="list-style-type: none"> 1. Check the control system 2. Check if the value of three-phase resistor is balance 3. Check if the connecting terminals are loosen 4. Check if the encoder is loosen
5	The traction ability is abnormal.	<ol style="list-style-type: none"> 1. Check if the rope match the traction sheave 2. Check if the force on the rope is equally

Appendix 2 Installation and deinstallation of the encoder

[1] Installation and deinstallation of the sleeve shaft encoder

Taking TAMAGAWA encoder OIH100 as an example, other types of sleeve shaft encoder should install and dismantle according to it.

there is a hole (its diameter is 30mm) in the middle of the encoder OIH100, it is match to the shaft, it convey the torque by a key, the encoder is fixed by two M4 screws.

When remove the encoder, first loosen the two M4 screws, then rotate the encoder by hand gently, and see if the encoder can be taken off totally, if it is, take it off along the shaft. You may refer to fig.2.1.

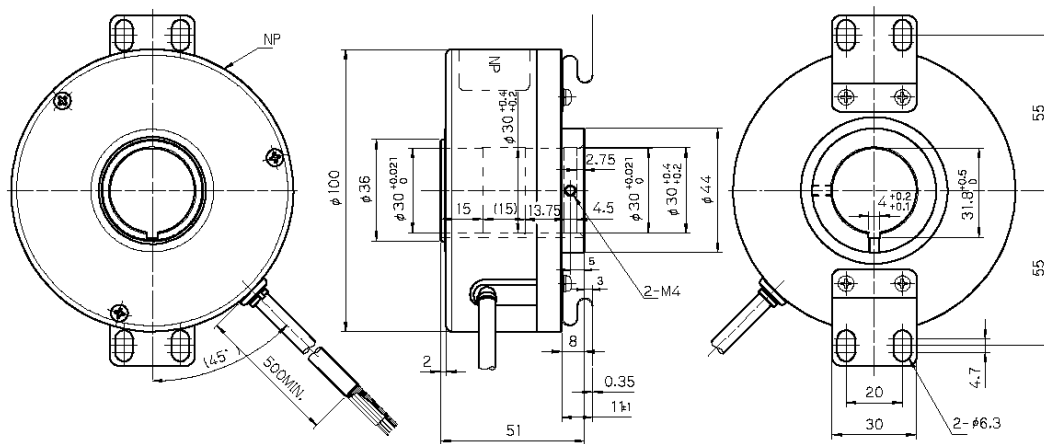

Fig. 2.1

[2] Installation and deinstallation of the countershaft encoder

2.1 Taking HEIDENHAIN encoder ERN 1387 as an example, other types of the countershaft encoder(the end of bolt for removing without slick rod) should install and dismantle according to it.

There is a taper in the front of the encoder shaft, put the encoder shaft into the hole of the shaft, make the encoder connect with the shaft by the puncturing bolts, fix the encoder on the shaft according to $M_d=5+0.5Nm$ by a hexagon spanner. Rotate the encoder, it should be very flexible at this time, tighten the expansion bolts according to $M_d=1.25Nm$ by a hexagon spanner, make the encoder outer cannot rotate by hand, insert the shielding wire (notice: the hoop of the shielding wire should be put into the cover groove) .Please refers to fig 2.2 and fig.2.3.

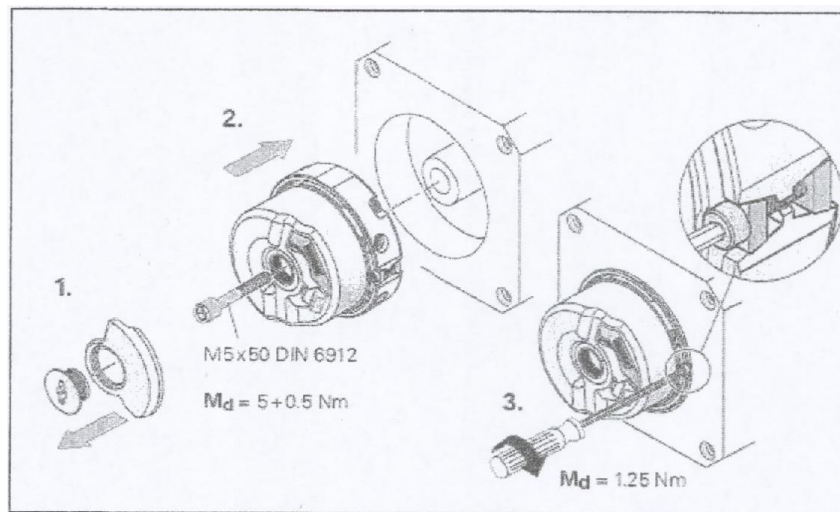

Fig. 2.2

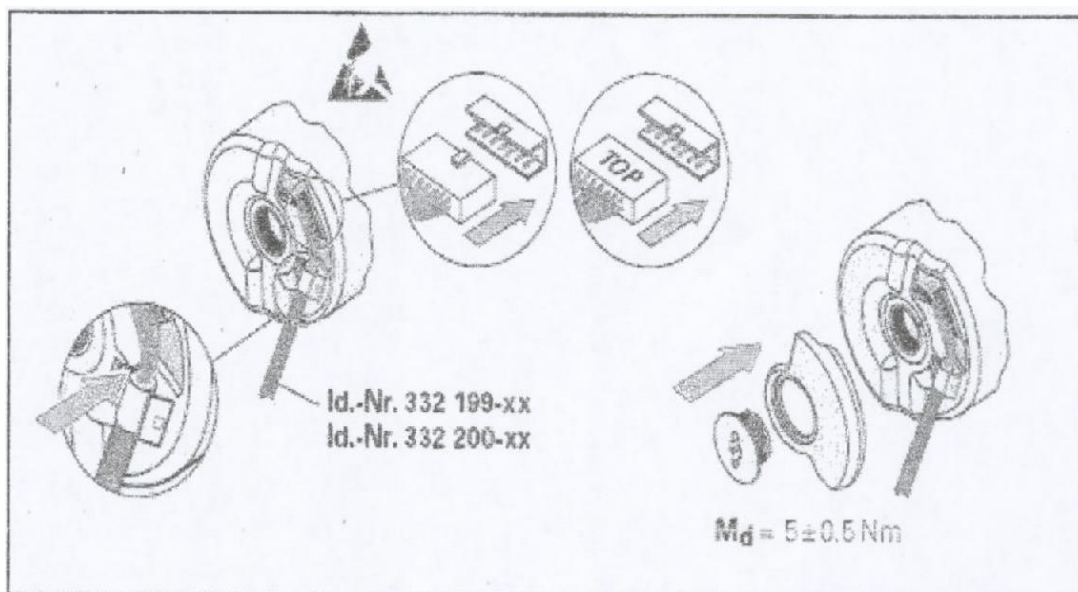

Fig. 2.3

When remove the encoder, take off the shielding wire, loosen the expansion bolts with the hexagon spanner, loosen the puncturing bolts (loosen two laps generally), then rotate the encoder gently, and see if the encoder is loosen totally, at last eject the encoder with a M10 bolt. Refer to fig.2.4.

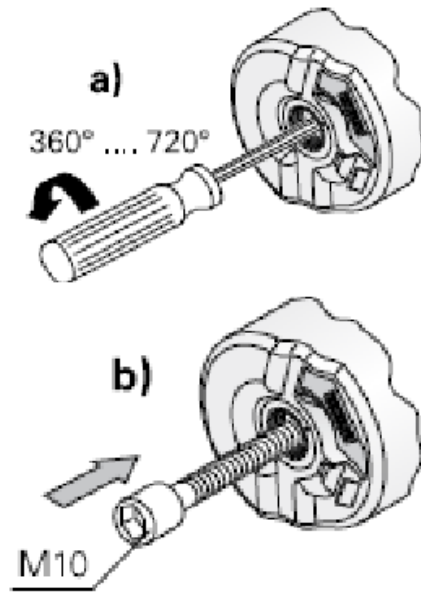

Fig. 2.4

2.2 Taking TAMAGAWA encoder OIH50 as an example, other types of the countershaft encoder(the end of bolt for removing with slick rod) should install and dismantle according to it.

The installation of TAMAGAWA encoder OIH50 is the same as HEIDENHAIN encoder 1387. When remove the encoder, take off the shielding wire, loosen the expansion bolts with the hexagon spanner, take out the puncturing bolt by turning it counter clockwise , at last eject the encoder with a M6 bolt.

Appendix 3 Instruction of the elevator hand-winding device

The traction machine use an elevator hand-winding suspension safety device which installs on the wall, refer to fig.3.1. There is a safety switch in the device and the switch is connected into the safety circuit in series. The advantage of this device is that when the hand wheel leave the wall-hanging device (refer to fig.3.2) on the wall, the safety circuit would be disconnected, so as to avoid the potential safety hazard, and make the safety risk drop to zero.

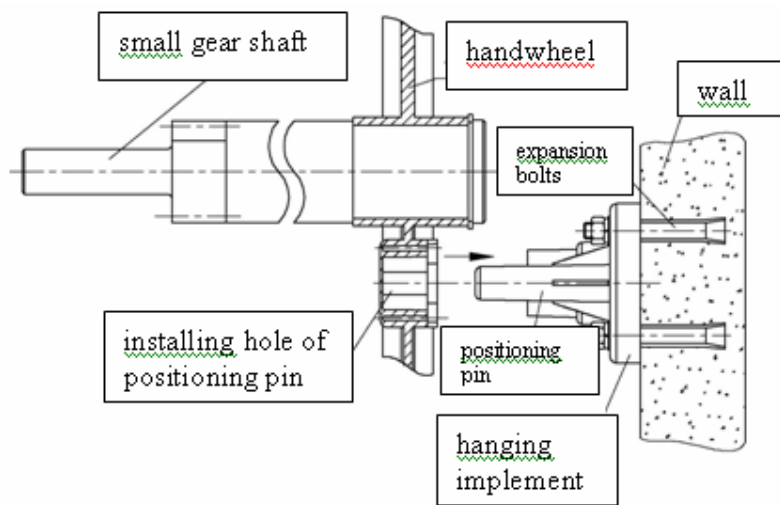

Fig.3.1



Fig. 3.2



Fig. 3.3

The wall-hanging device is fixed on the machine room wall, two holes of the handwheel point the two cylinders of the wall-hanging device, push the hand wheel into the wall-hanging device in place horizontally (with smaller force, in the direction of arrow, refer to fig.3.1), the handwheel would hang on the wall reliably, and the pin is inserted to avoid the hand wheel slipping. At the same time, make up the hand-winding contact point and wall-hanging device as a switch, and connect into the elevator safety circuit in series, the elevator may work normally.

When the elevator stopped under the abnormal situation, there is a need for emergency operation of the elevator car movement. First, pull the handwheel pin out. When the handwheel pulled out(strong force) from the wall –hanging device to use horizontally, the connector switch disconnected whit the elevator safety circuit. In another words, when the handwheel just left the wall-hanging device, the elevator safety circuit was disconnected immediately. Then the handwheel can be used safety and normally. Insert the small gear of the handwheel into the installing hole of the base to jigger, refer to fig.3.3. When jigger is over, put the handwheel back to the wall-hanging device, then the elevator safety circuit is connecting, the elevator may work normally.

Fix the wall-hanging device on the wall by the four M6 expansion bolts reliably. Perforate in the wall. size refer to fig.3.4 (unit: mm) :

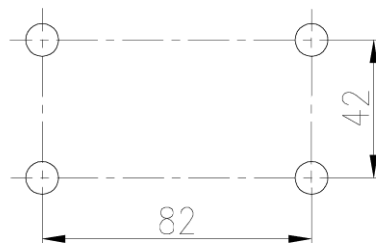

Fig. 3.4

Appendix 4 Method of change the traction machine operation direction

After the traction machine installation, the encoder should have phase angle self-study, when the self-study is over successfully, click run to judge if the machine operation direction and the car running direction are the same. If not, please do according to the control system manual, you may consult the manufacturer engineer when necessary. The ways to change the machine operation direction is for your information, but they are not suitable in some cases:

1. Interchange power line V and W between the machine and the transducer.
2. Interchange A^+ and A^- , V^+ and W^+ , V^- and W^- of the encoder lead wire. Only interchange A^+ and A^- , C^+ and C^- for sine cosine encoder (such as HEIDENHAIN encoder).
3. When interchange wire is over, it needs to begin self-study again, to change the machine operation direction.